

MONTAGEANLEITUNG

ASSEMBLY INSTRUCTIONS

NOTICE DE MONTAGE

MONTAGEHANDLEIDING

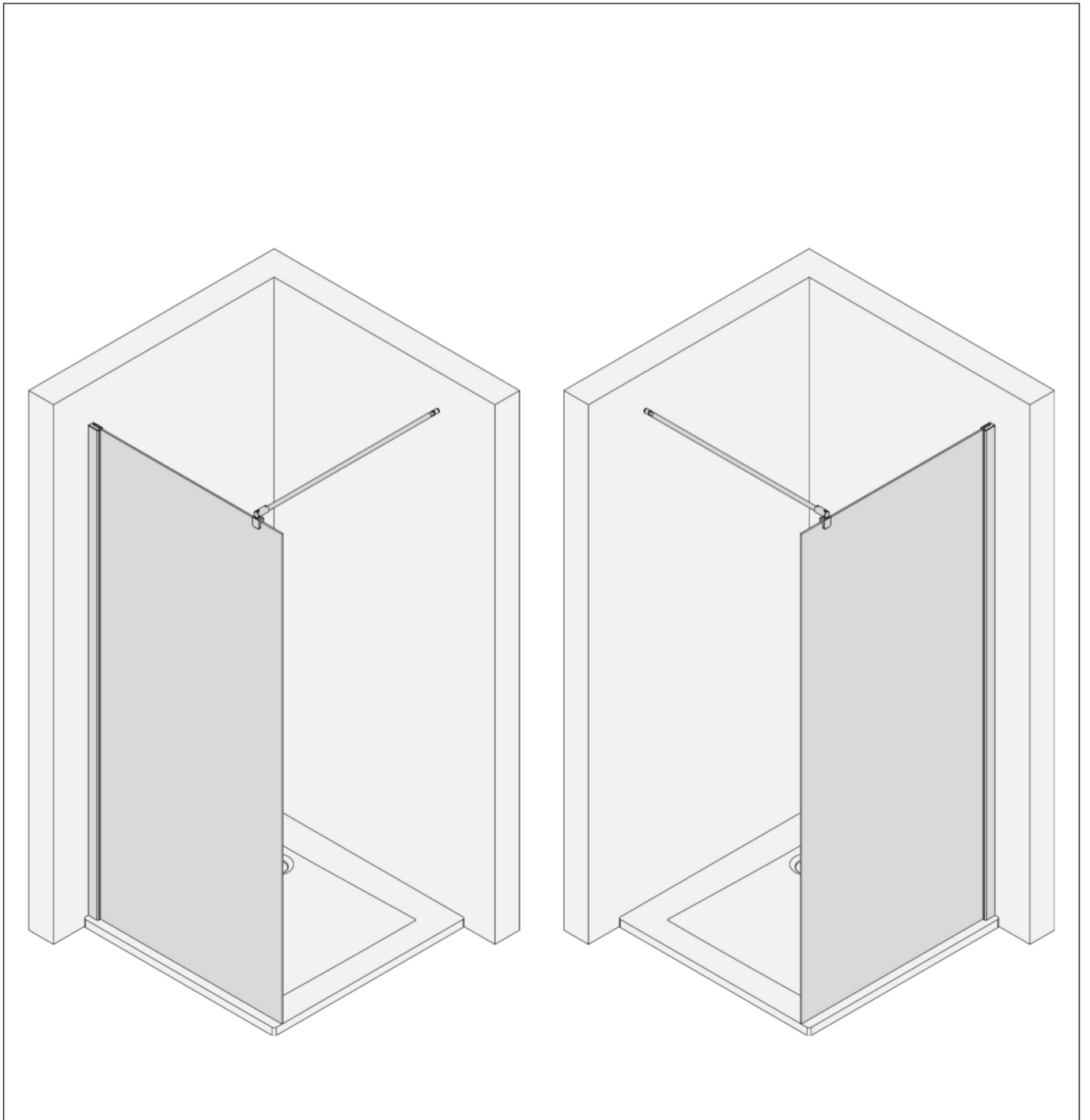



SICHERHEITSHINWEISE / SAFETY INSTRUCTIONS CONSIGNES DE SÉCURITÉ / VEILIGHEIDSINSTRUCTIES

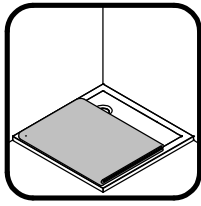

- de** Decken im Arbeitsbereich auslegen
- en** Cover the shower tray completely
- fr** Couvrez complètement le bac de douche
- nl** Bedek de douchebak volledig



- de** Schutzbrille tragen
- en** Wear safety goggles
- fr** Portez des lunettes de protection
- nl** Veiligheidsbril dragen

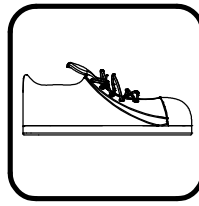

- de** Sicherheitsschuhe tragen
- en** Wear safety shoes
- fr** Portez des chaussures de sécurité
- nl** Veiligheidsschoenen dragen

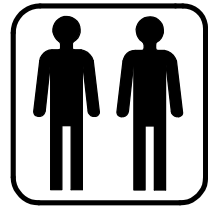

- de** Empfohlene Montage mit 2 Personen.
- en** Assembly recommended with 2 persons
- fr** Montage recommandé avec 2 personnes
- nl** Aanbevolen montage met 2 personen

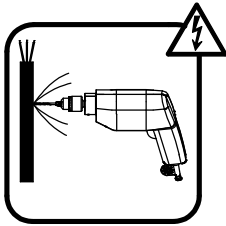

- de** über die Lage der Stromleitung informieren
- en** get information about the location of the power line
- fr** Informez-vous sur l'emplacement de la ligne électrique
- nl** Informeren over de locatie van de hoogspanningslijn

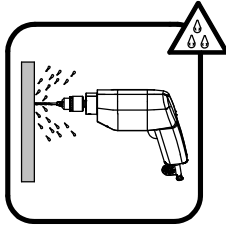

- de** über die Lage der Wasserleitung informieren
- en** get information about the location of the water pipe
- fr** Informez-vous sur l'emplacement de la ligne d'eau
- nl** Informeren over de locatie van de waterleiding



- de** Glas schützen
- en** Protect glass
- fr** Protégez le verre
- nl** Glas beschermen

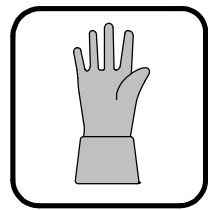

- de** Handschuhe mit Pulsschutz tragen
- en** wear gloves with pulse protection
- fr** portez des gants avec protection du poignet
- nl** Draag handschoenen met polsbescherming

HINWEIS / NOTE / NOTE / NOOT

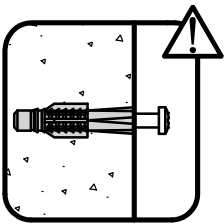

- de** Vor Montage die Beschaffenheit des Mauerwerks überprüfen. Gegebenenfalls ist das im Lieferumfang enthaltene Befestigungsmaterial nicht für die Befestigung geeignet.
- en** Check the condition of the masonry before installation. The fixing material included in the scope of delivery may not be suitable for fixing.
- fr** Vérifiez l'état de la maçonnerie avant le montage. Il se peut que le matériel de fixation inclus dans la livraison ne soit pas adapté à la fixation.
- nl** Controleer de staat van het metselwerk vóór de installie. Het is mogelijk dat het bij de levering inbegrepen bevestigingsmateriaal niet geschikt is voor bevestiging.

- de** Die Aufstellfläche der Duschkabine muss eben sein.
- en** The installation surface of the shower enclosure must be level.
- fr** La surface d'installation de la cabine de douche doit être plane.
- nl** Het montagevlak van de douchewand moet waterpas zijn.

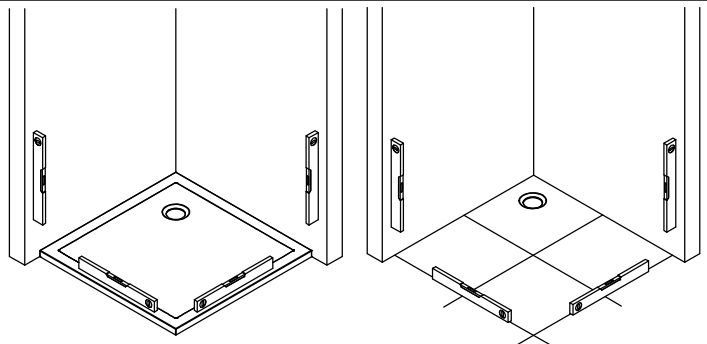

ANSCHLAG / STOP / ARRÊT / STOP

de Bei der Duschkabine gibt es einen "Anschlag". Als Anschlag wird die Seite bezeichnet, an der die Türscheibe an die Wand montiert wird.

Es gibt zwei Arten von Anschlägen: Anschlag links (a) und Anschlag rechts (b).

In dieser Montageanleitung wird der Aufbau "Anschlag links" dargestellt. Die Montageschritte für Anschlag rechts sind dann spiegelbildlich durchzuführen.

en Every shower enclosure has a "fixation side". The "fixation side" is the side where the door panel is mounted on the wall.

There are two possible fixation sides: fixation on the left (a) and fixation on the right (b).

This assembly instruction describes an assembly with "fixation on the left". The assembly steps on the right are then to be carried out in mirror image.

fr Chaque cabine de douche a une "côté de fixation". Le "côté de fixation", c'est le côté sur lequel la vitre de la porte est montée sur le mur.

Il y a deux côtés de fixation possible: fixation gauche (a) et fixation droite (b).

Cette notice de montage montre un montage avec "fixation gauche". Les étapes de montage à droite doivent alors être effectuées à l'envers.

nl Bij elke douchewand is er een "montagezijde". "Montagezijde" is de zijde waaraan het deurpaneel aan de muur is bevestigd.

Er zijn twee soorten montagezijden: montagezijde links (a) en montagezijde rechts (b).

Deze montagehandleiding toont de montage "montagezijde links". De assemblagestappen aan de rechterzijde moeten dan in spiegelbeeld worden uitgevoerd.

a

b

Anschlag links
stop left
arrêt à gauche
stop links

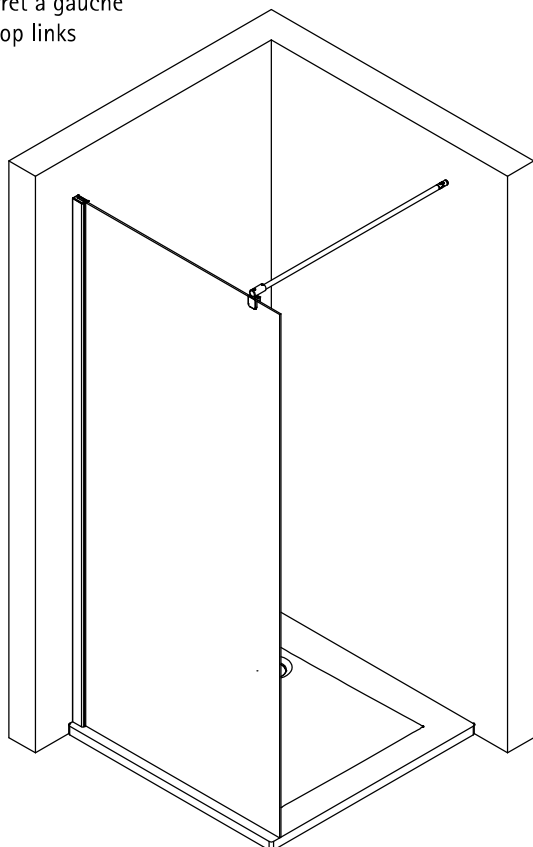

Anschlag rechts
stop right
arrêt à droite
stop rechts

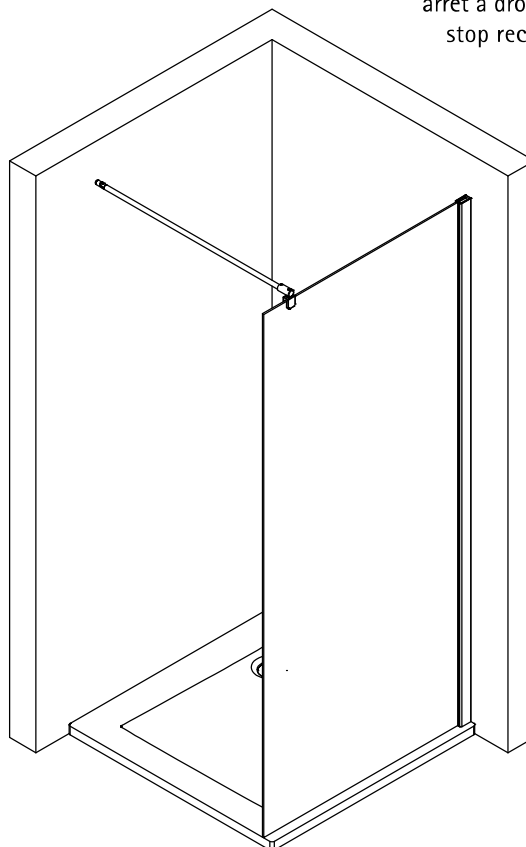

MAßE / DIMENSIONS / DIMENSIONS / AFMETINGEN



- de** prüfen, ob gemessene Maße den Tabellenwerten (X) entsprechen
- en** check if measured dimensions correspond to the table values (X)
- fr** vérifier si les dimensions mesurées correspondent aux valeurs du tableau (X)
- nl** controleren of de gemeten afmetingen overeenkomen met de tabelwaarden (X)

de Montage auf Duschwanne

fr Montage sur receveur de douche

en Mounting on shower tray

nl Montage op douchebak

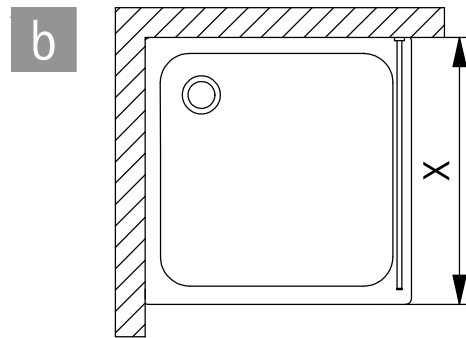
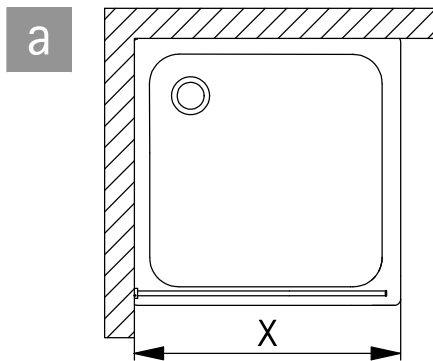

	X
900 mm	875 - 900 mm
1000 mm	975 - 1000 mm
1200 mm	1175 - 1200 mm
1400 mm	1375 - 1400 mm
1600 mm	1575 - 1600 mm

de Montage auf Fliese

fr Montage sur carrelage

en Mounting on tile

nl Montage op tegel

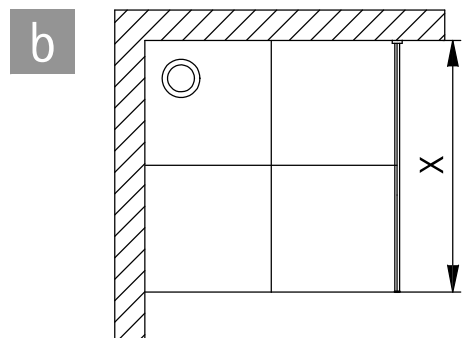
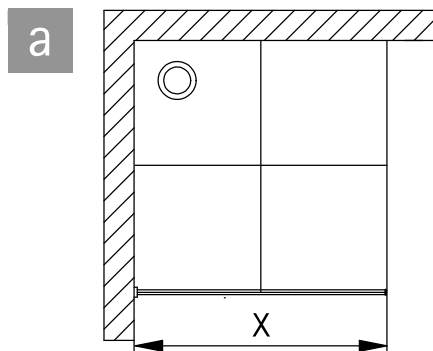

	X
900 mm	-
1000 mm	-
1200 mm	-
1400 mm	-
1600 mm	-

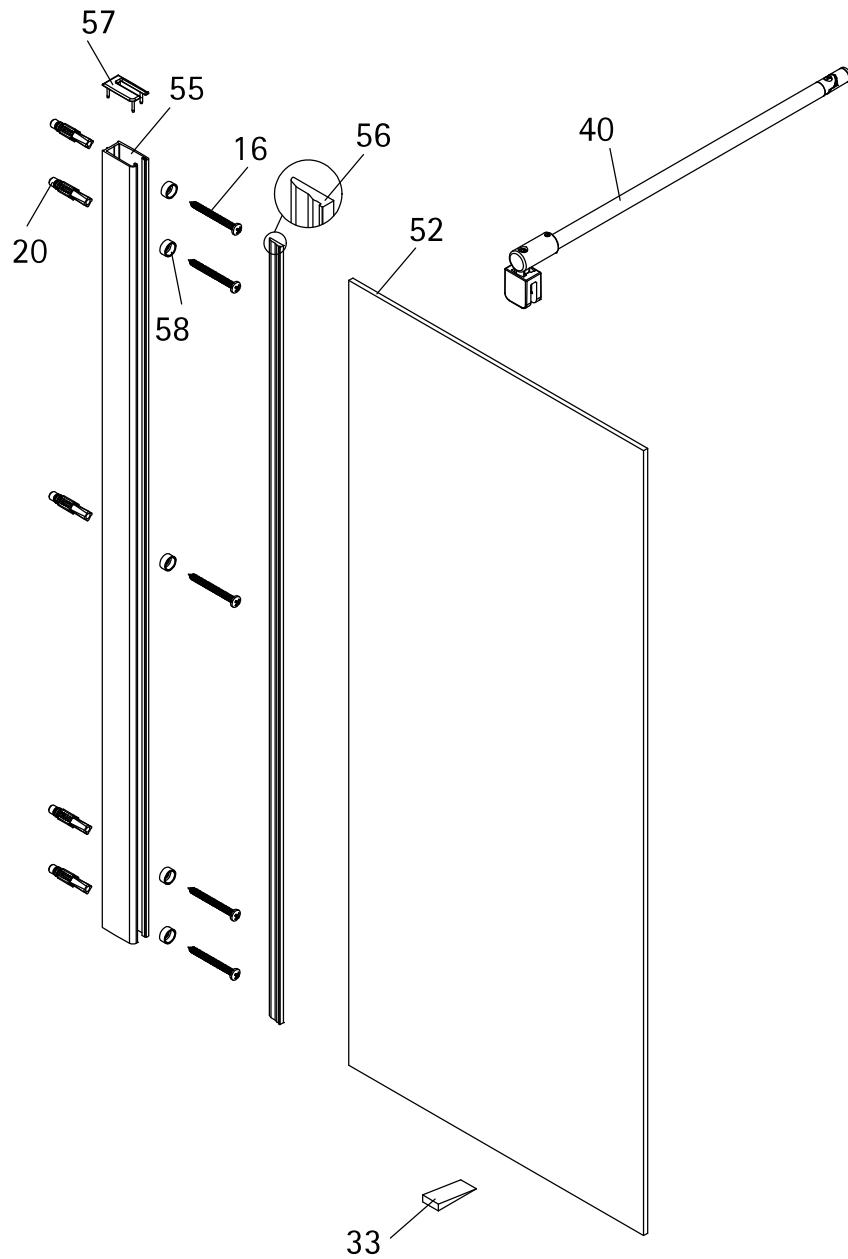

Pos.	Bezeichnung	Ersatzteil-Nr.	Preis	Pos.	Bezeichnung	Ersatzteil-Nr.	Preis
16*	5x Linsenblechschraube 4,2 x 45mm			56	1x Klemm-Dichtprofil	E100071	Stück 24,95 €
20*	5x Dübel Ø 6mm			57	1x Abdeckkappe	E85205-3	Set 11,95 €
33	1x Silikonkeil (6 Stück)	E100203	Set 16,95 €	58*	5x Glasschutz		
40	1x Stabilisationsbügel rund	E100320	Stück 46,95 €				
52	1x Frontscheibe				* Schrauben und Abdeckkappenset	E85200-3	16,95 €
55	1x Wandanschlussprofil	E100230-9	Stück 86,95 €				

de Geben Sie bei farbigen Ersatzteilen den Farbcode mit an: 01 - Alu | 04 - weiß | 41 - chrom | 68 - schwarz | 90 - Edelstahl

en Please state the colour code for coloured spare parts: 01 - aluminium | 04 - white | 41 - chrome | 68 - black | 90 - stainless steel

fr Veuillez indiquer le code couleur pour les pièces de rechange colorées : 01 - aluminium | 04 - blanc | 41 - chrome | 68 - noir | 90 - acier inoxydable

nl Gelieve de kleurcode voor gekleurde onderdelen te vermelden: 01 - aluminium | 04 - wit | 41 - chrom | 68 - zwart | 90 - roestvrij staal

BENÖTIGTES WERKZEUG / TOOL NEEDED
QUITILAGE NECESSAIRE / BENODIGD GEREEDSCHAP

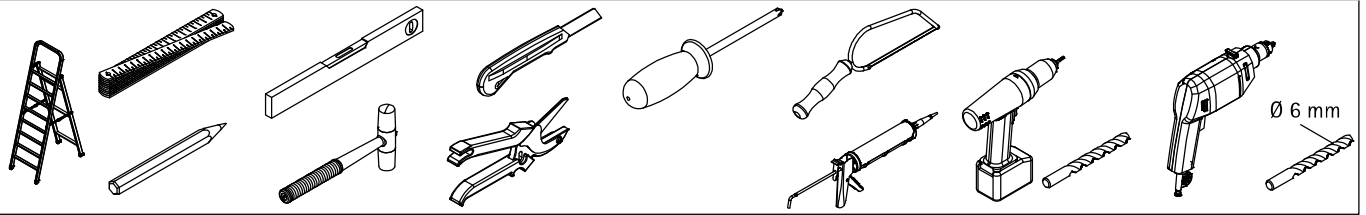

MONTAGE / ASSEMBLY / ASSEMBLÉE / ASSEMBLAGE

1

a

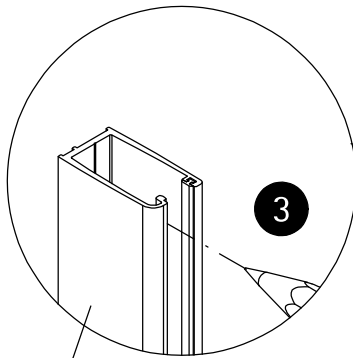
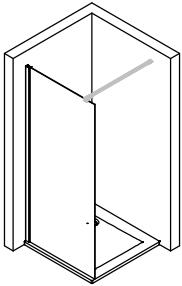

Pos. 55

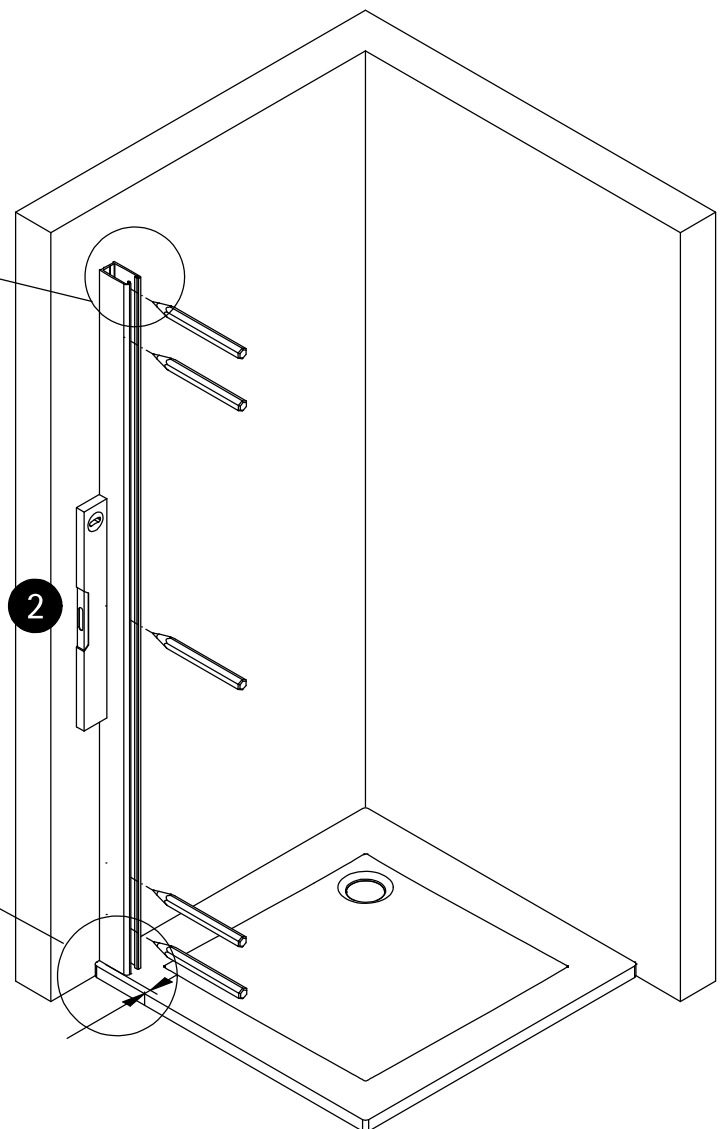
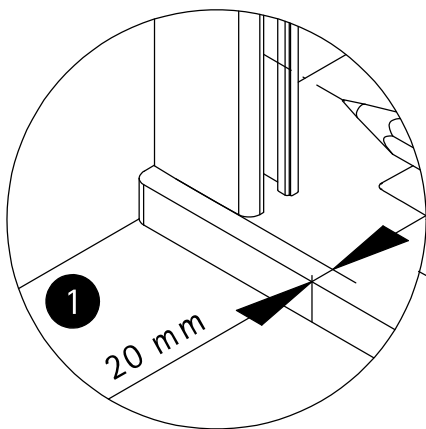

2

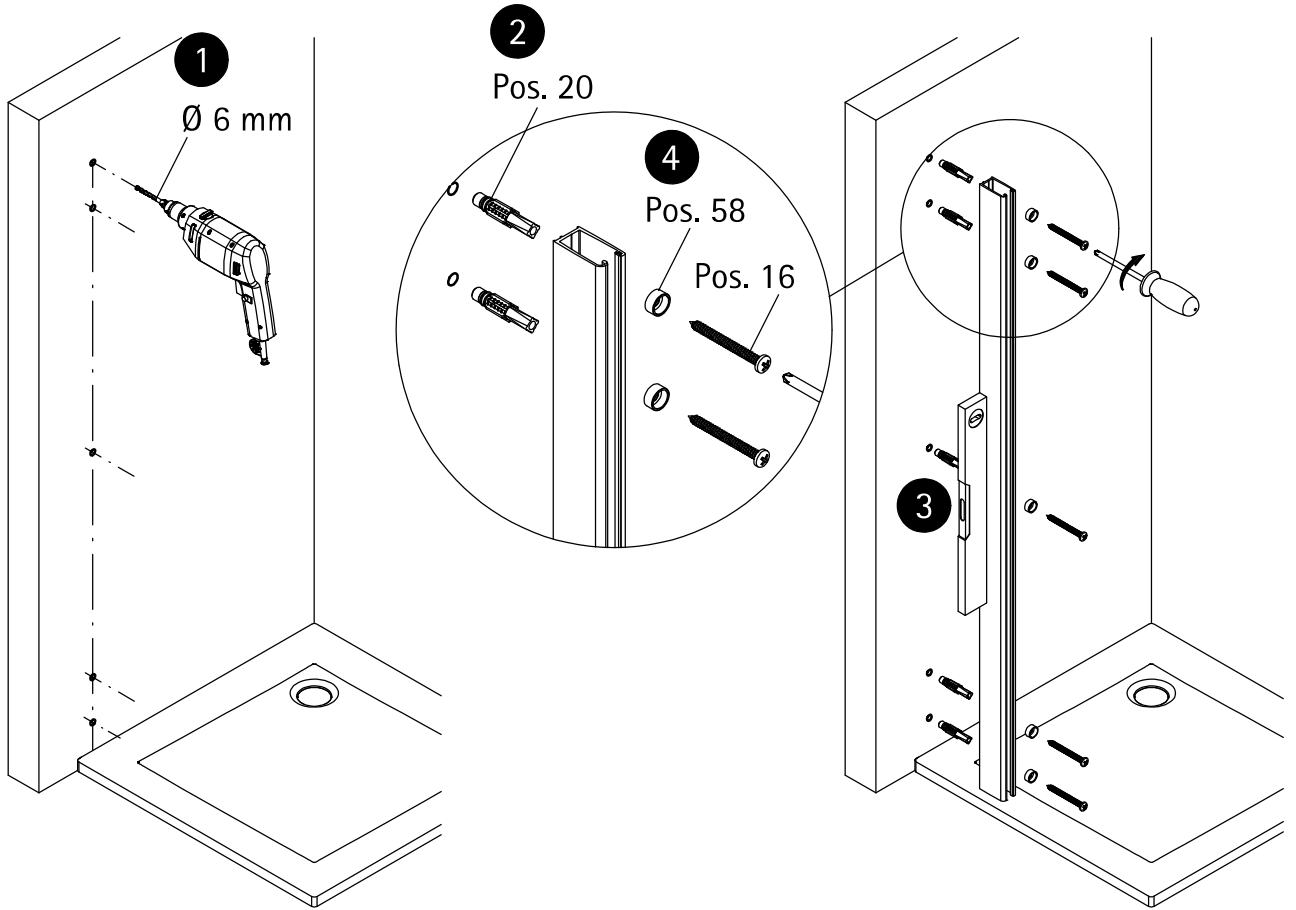

3

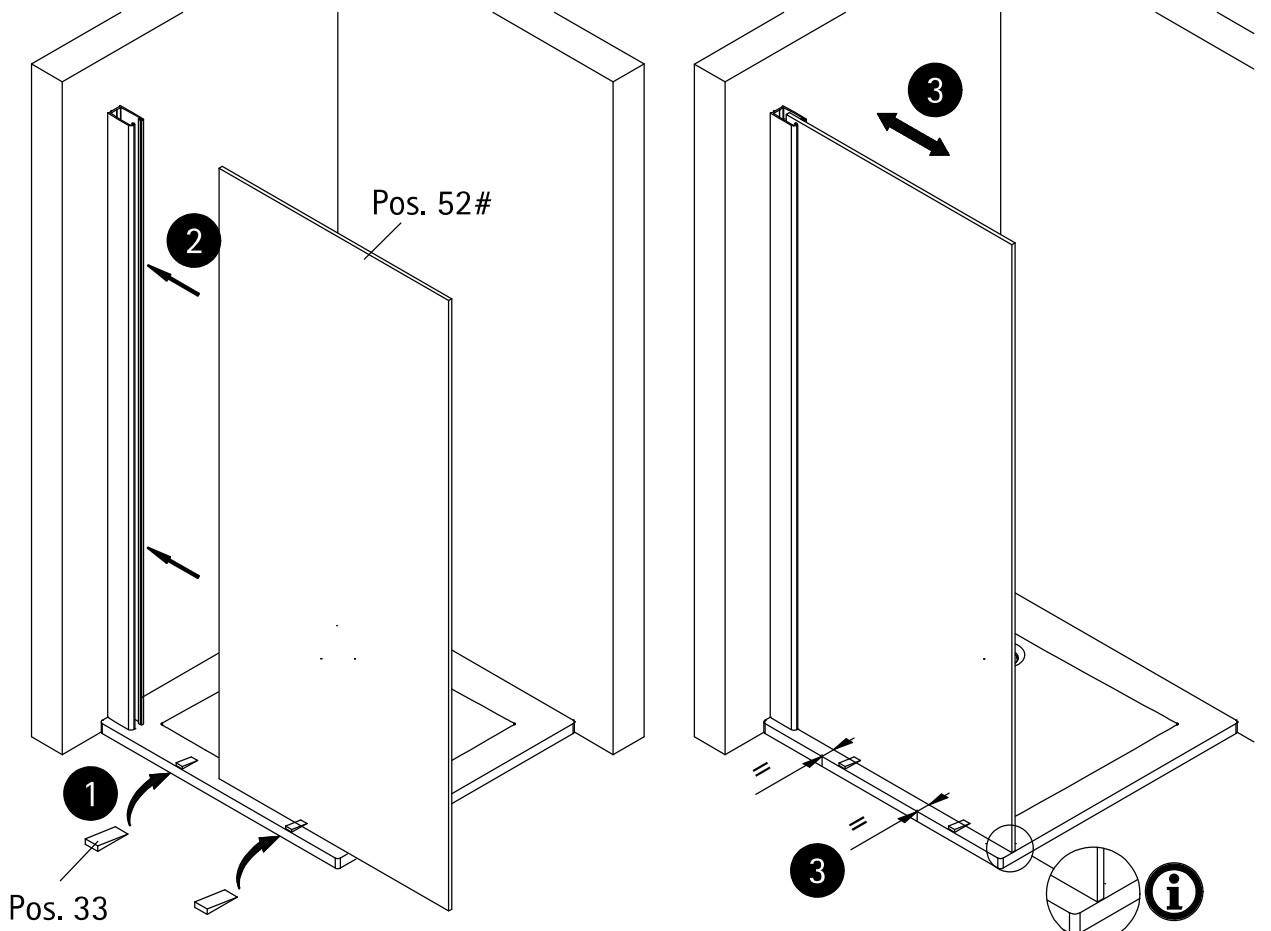

4

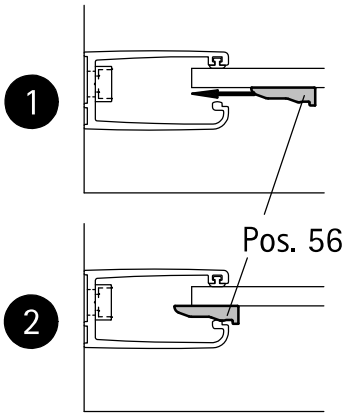
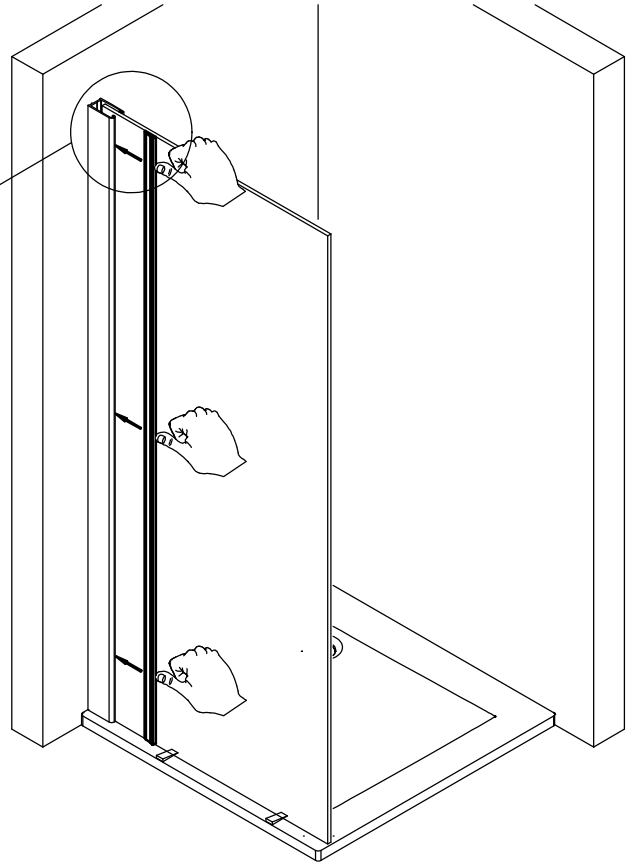
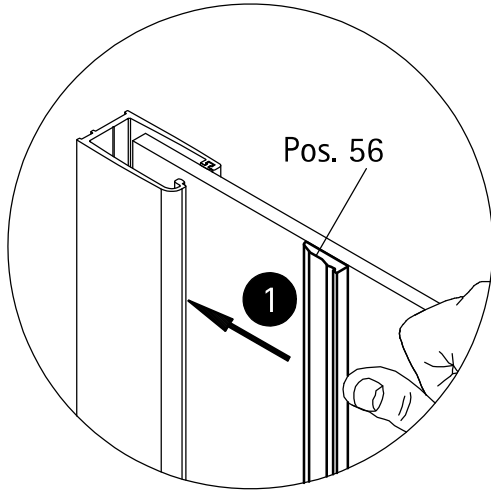

5

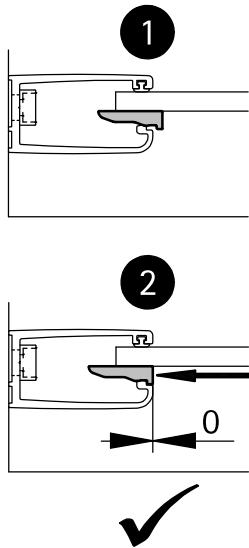
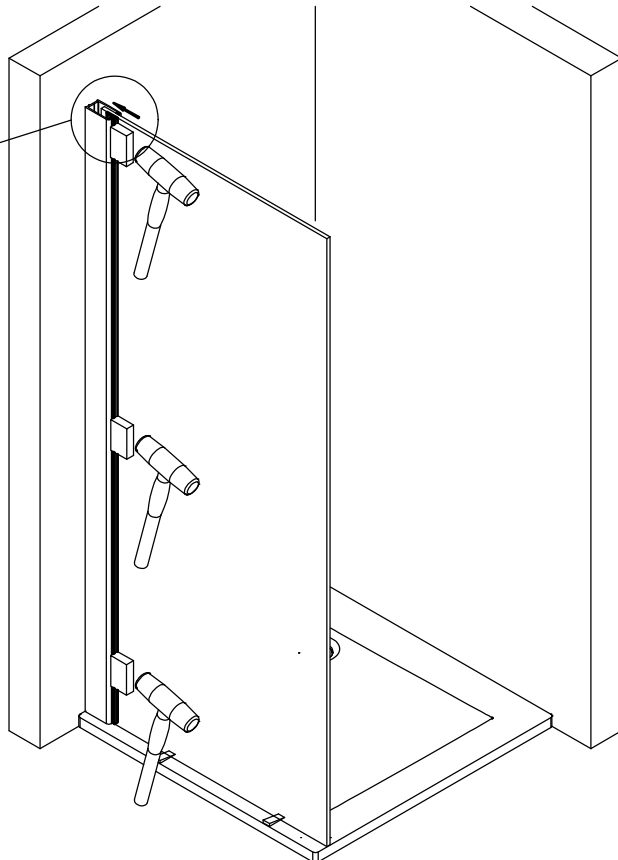
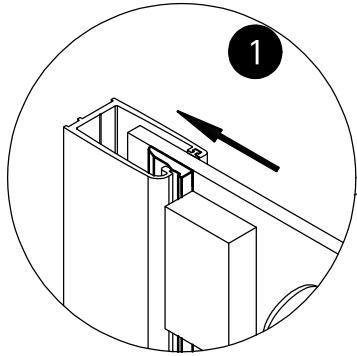

6

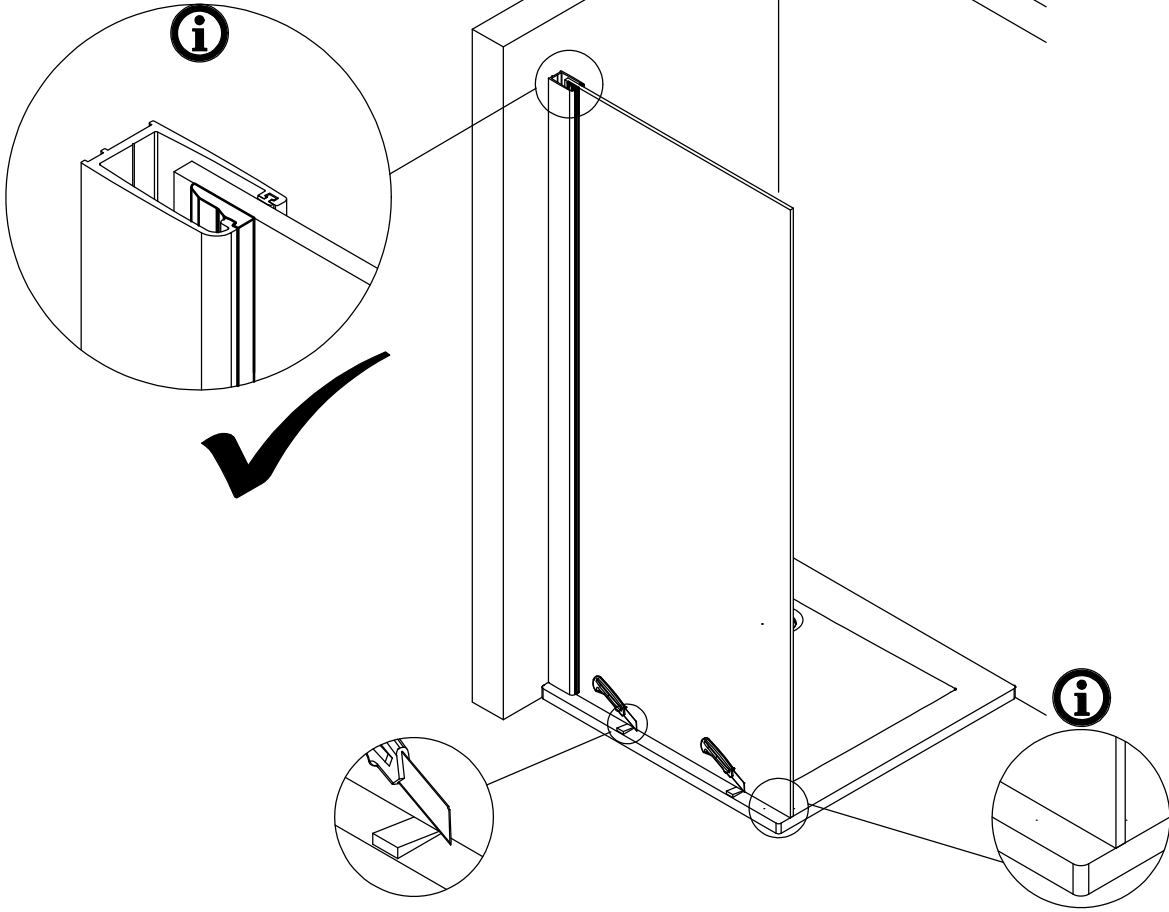

7

Pos. 57

Pos. 40

60 mm

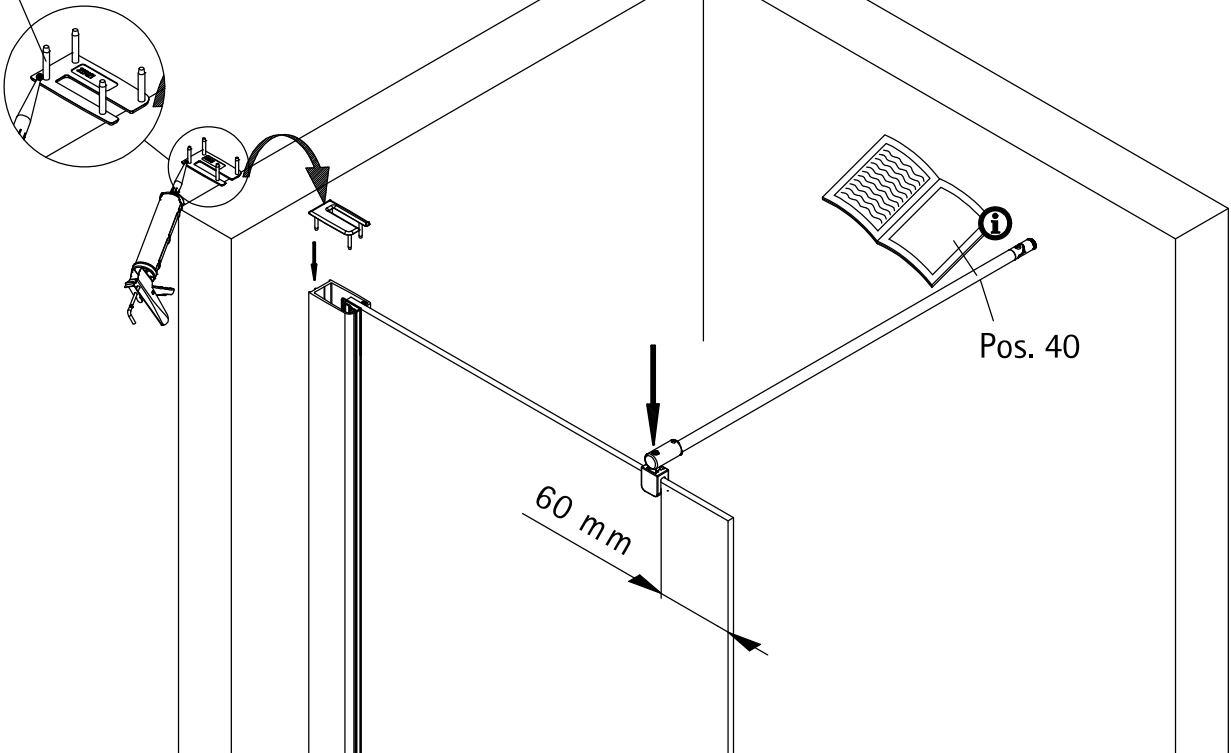

8

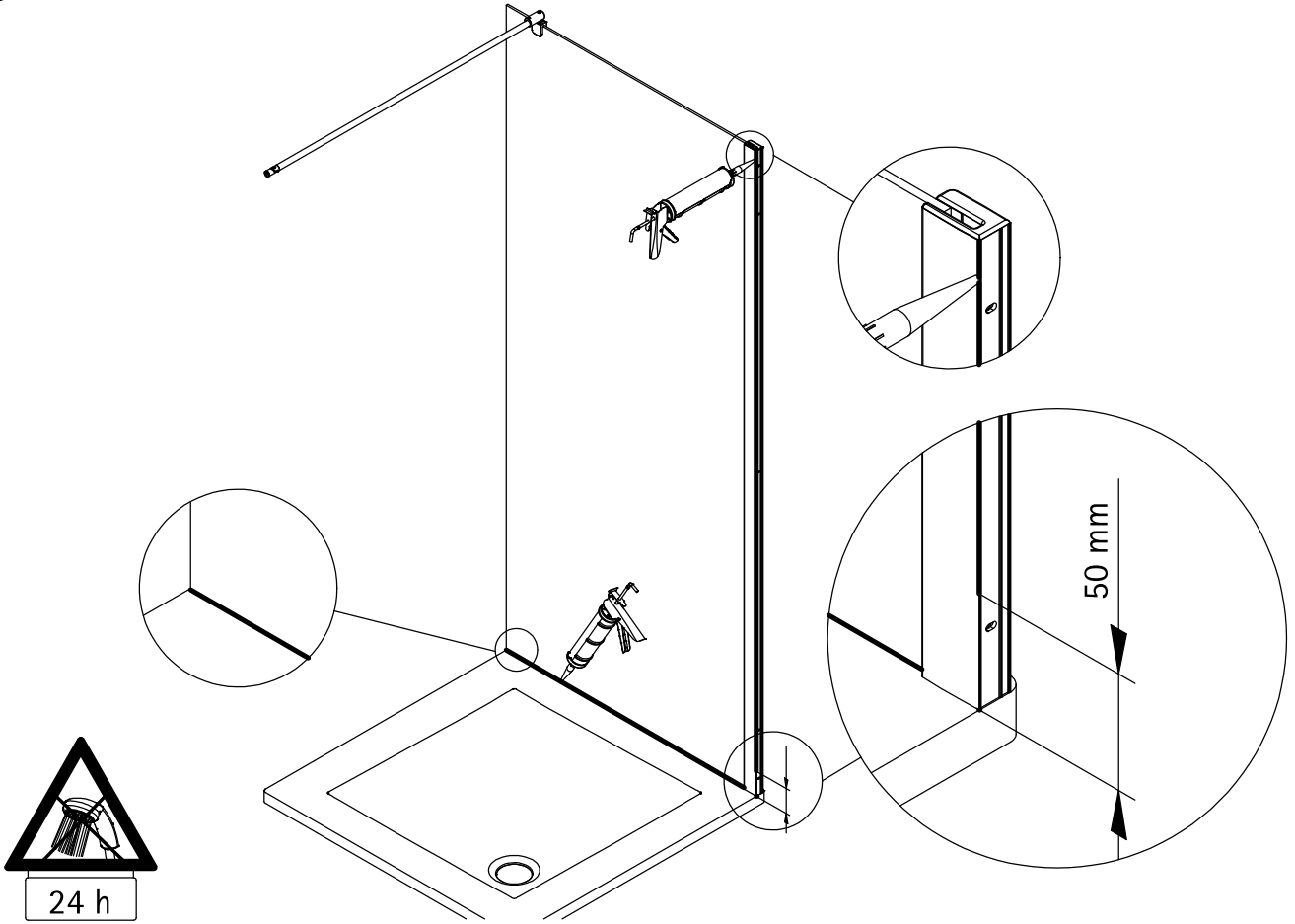

9

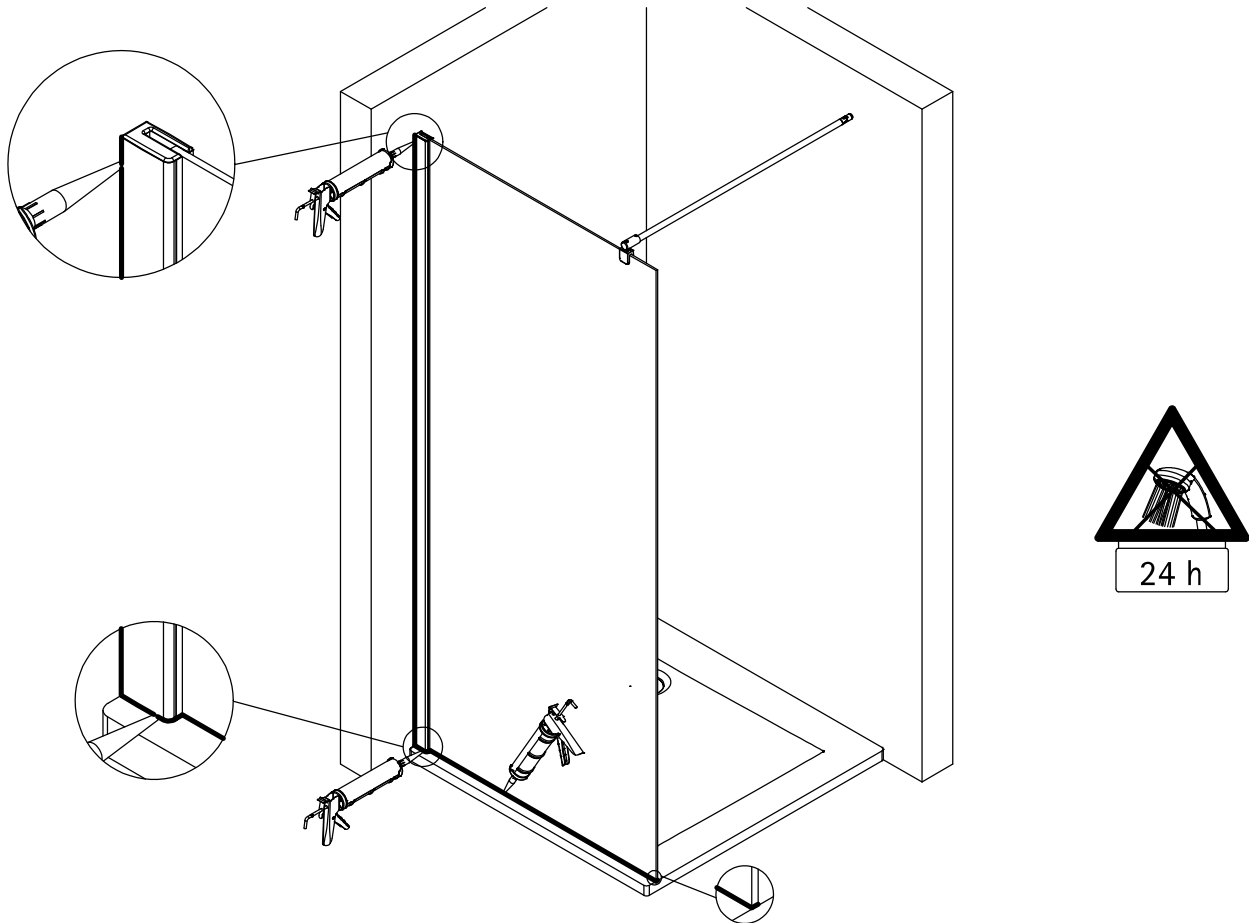

Notizen, notes, notities

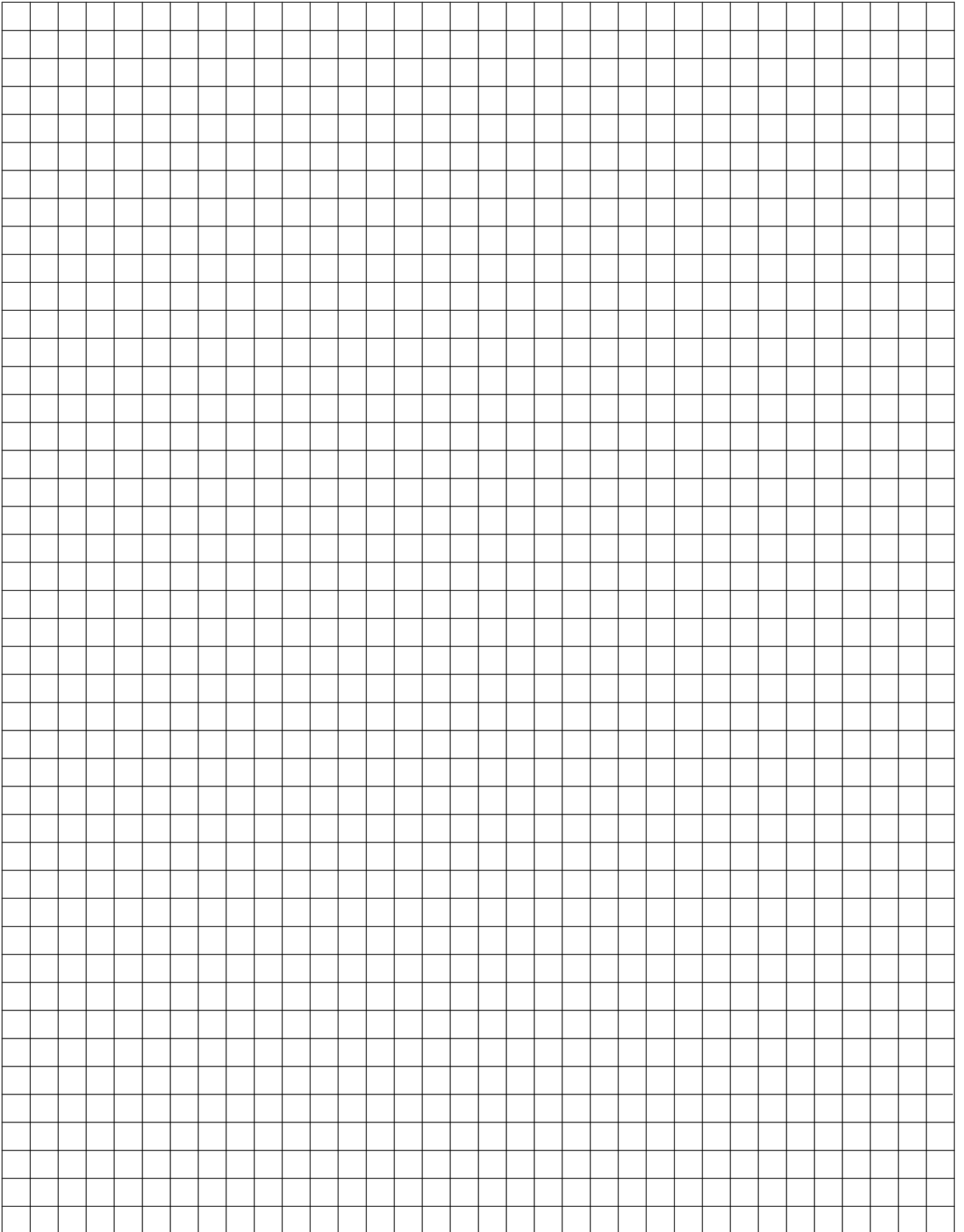

2118-2

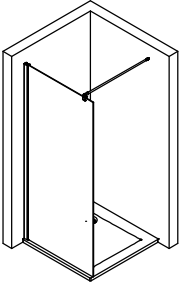

Prüfnummer / Inspection number / Numéro d'essai / Controlnummer



Ersatzteilbestellung / spare parts order
commande de pièces de rechange / Bestelling van reserveonderdelen:
Fax 02962 / 972-4260



Technische Hilfe / technical help / l'aide technique / technologische ondersteuning
Telefon 02962 / 972-40



E-Mail:
ersatzteile@duschservice.de



Duschservice
Zum Hohlen Morgen 22
59939 Olsberg
Deutschland / Germany / Allemagne / Duitsland

